

## JÄMERÄ KIVITALOT – GENERAL TERMS OF DELIVERY

These general terms of delivery apply to all Jämerä deliveries. In addition to Jämerä's general terms and conditions, deliveries are subject to the terms of contract drawn up by the Finnish Association for Manufacturers of Prefabricated Houses and reviewed and approved by the Consumer Om-buds-man, entitled *General terms of contract for the consumer sale and installation of prefabricated houses and elements*, which are provided to the Client as an appendix to the quote. Hereinafter, these are referred to as the General Terms of Contract.

These general terms of delivery supplement the aforementioned General Terms of Contract. The matters referred to in this document are the prerequisites for ensuring that deliveries are carried out as planned and to the agreed timetable. Careful familiarisation with the general terms of delivery is very important for the smooth execution of the construction project and the avoidance of excess costs.

### Terms used in this document

<b>Client</b>	The client who ordered the Jämerä delivery. A party engaging in the construction project in accordance with the Land Use and Building Act.
<b>Delivery Manager</b>	The Client's designated contact person in relation to deliveries by Jämerä Kivitalot Oy.
<b>Principal Designer</b>	A designer who is selected by the Client and who is responsible for the overall planning of construction in accordance with the Land Use and Building Act.
<b>Principal Structural Designer</b>	A specialised designer responsible for the structural design of the house. A principal structural designer must be appointed for the site before applying for a building permit.
<b>Site Manager</b>	The site manager who is selected by the Client and who monitors the implementation of the work. The site manager manages the construction work and is responsible for ensuring that the party engaging in the construction project takes the statutory and prescribed measures.
<b>Jämerä</b>	Jämerä Kivitalot Oy.
<b>Order</b>	A document signed by Jämerä's sales representative and the Client to confirm that the quote and its appendices and any additions are accepted as an order. The document is delivered to Jämerä for confirmation.
<b>Order Confirmation</b>	The document that Jämerä sends to confirm that the Order and its appendices have been received and accepted.
<b>Content of Delivery Appendix</b>	A document appended to the quote showing the content of the delivery and the matters for which Jämerä is responsible. The Client approves the document by signing the Order. The Content of Delivery Appendix contains revisions to the terms of delivery concerning the specific content of the delivery. The contents of Jämerä's deliveries are unique. Deliveries may include various products, design and installation. Changes and revisions in the Content of Delivery Appendix may be proposed in the Order.
<b>Delivery Plan</b>	A concept that refers to the content of the delivery, the method of delivery, and the scheduling.
<b>Main Drawings</b>	The drawings appended to the building permit application, containing enough detail to evaluate whether they fulfil the construction regulations and provisions and the requirements of good construction practice. Other reports and calculations are also required for the building permit, and

those supplied by Jämerä are listed in the Content of Delivery Appendix to the confirmed Order.

**Structural Design**

More detailed drawings for the construction of the building.

**General Terms of Contract**

The “General terms of contract for the consumer sale and installation of prefabricated houses and elements” drawn up by the Finnish Association for Manufacturers of Prefabricated Houses and reviewed and approved by the Consumer Om-buds-man.

**ORDER CONFIRMATION**

The Order Confirmation is the most important contract document between the Client and Jämerä, and it shall be first in the order of interpretation. If any part of the Order Confirmation does not correspond to the agreement, the Client must immediately contact the Delivery Manager.

The agreement between Jämerä and the Client shall take effect on the date stated on the Order Confirmation. If Jämerä proposes changes or additional terms relating to the Order in its Order Confirmation, the agreement shall take effect on the date after the Order Confirmation date when the Client has approved it.

After the Order Confirmation is delivered, all communications should be handled via Jämerä’s designated Delivery Manager. Written communication to Jämerä should take place primarily by email or other digital systems managed by Jämerä.

If the content or method of delivery changes after the inception of the agreement for a reason attributable to the Client, Jämerä shall charge for the price impact of the change and prepare a separate change or additional price calculation for the Client’s approval. It should be noted that changes often have knock-on effects on other building components, and these changes incur costs. The costs of change planning shall be determined according to the hourly price for design work and included in the calculation. Jämerä reserves the right to alter the Delivery Plan for changes due to the Client.

**BUILDING PERMIT APPLICATION AND MAIN DRAWINGS**

The architect appointed for the construction site shall prepare the Main Drawings for the site, and the Principal Designer and Client shall use the Main Drawings to apply for a building permit. Depending on the Order, the Main Drawings may be included in the content of Jämerä’s delivery, or the Client may order them directly from the architect.

The Jämerä house shall be designed in accordance with Jämerä’s design guidelines and structural solutions. When a building permit is received for the site, a copy of the building permit shall be delivered to Jämerä’s Delivery Manager. The Client shall also notify Jämerä’s Delivery Manager of the names and contact details of the Principal Designer and Site Manager.

Figure 1 illustrates the estimated timetable for preparing designs and calculations before a building permit is granted.

**Actions following Order Confirmation before receiving a building permit:**

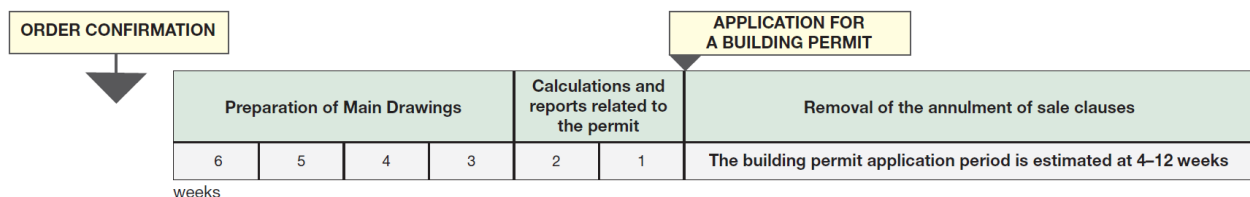

Figure 1. Estimated time required for the preparation of the Main Drawings and for calculations and reports related to the building permit

**REMOVAL OF THE ANNULMENT OF SALE CLAUSES**

If the Order Confirmation includes annulment of sale clauses, the Delivery Manager shall be notified in writing of the removal of the clauses before the associated deadline by submitting the clause removal form provided with the Order Confirmation. The removal or lapsing of the clauses shall serve as final confirmation of the agreed sale, and it is a prerequisite for the delivery process to progress according to the planned timetable.

**STRUCTURAL DESIGN**

The Jämerä house’s structural design shall correspond to Jämerä’s design guidelines and structural solutions. For the purpose of Jämerä’s structural design, the Client shall deliver the initial data specified in the Content of Delivery Appendix to Jämerä’s Delivery Manager before structural design begins.

The Client shall be responsible for the accuracy of any drawings, designs and other documents that the Client orders from parties other than Jämerä, as well as for any necessary approval from the authorities. The Client shall submit such documents to Jämerä when they have been completed. Jämerä shall review the designs and reserves the right to demand structural changes to the supplied designs and to the pricing of the delivery if the designs differ from those used as the basis for the quote.

**DELIVERY TIME**

The Order Confirmation states a preliminary start time for deliveries to the construction site. At this stage, the week during which deliveries are to start is an estimate because it depends on issues for which the Client is responsible, such as the time taken to prepare the building permit application, receive the building permit, and remove any annulment of sale clauses, if applicable. The final delivery time will also be affected by the time spent on structural design and, among other things, the progress of earthworks. The Client may contribute to completing the delivery within the estimated time by taking the measures required by the permit plans and building permit application without delay. Figures 1 and 2 illustrate the timetable for the order and delivery.

Jämerä shall revise the starting week for construction site deliveries, if necessary, after any applicable annulment of sale clauses applying to the Order have been removed or have lapsed and a building permit has been received for the site. The revised starting week for construction site deliveries shall be at least **12 weeks** after the removal of the annulment of sale clauses, granting of the building permit and submission of the initial data for structural design to the Delivery Manager.

Jämerä shall confirm the final delivery time when the Structural Designs have been completed and approved by the Client and Jämerä. The confirmed starting week for construction site deliveries shall be at least **4 weeks** from this date. The corresponding period for prefabricated elements shall be at least **7 weeks**.

The starting week for deliveries stated on the delivery time confirmation shall be binding on both contractual parties. After the delivery time is confirmed, changes to the content of the delivery shall no longer be possible without changes to the timetable and costs. The costs incurred due to delays or changes in deliveries shall be subject to compensation in accordance with the General Terms of Contract applying to the sale. Changes related to the Delivery Plan shall always be agreed upon in writing with the Delivery Manager.

**Measures to be taken when the building permit is granted:**

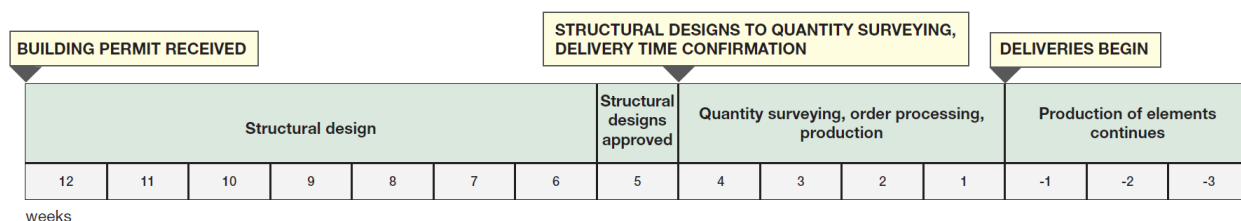

Figure 2. Estimated time after the building permit is granted and the annulment of sale clauses, if applicable, are removed and before construction site deliveries begin

**ENSURING THE ROADWORTHINESS OF THE ROAD**

The Client is obliged to ensure that there is a road to the place where materials are unloaded and stored and that the road can be used to transport the products using lorries with semi-trailers or full trailers. The road must have an adequate load-bearing capacity, and it must not be too steep for the said vehicles. During the winter and times of poor driving conditions, the Client shall plough the snow, grit the road and ensure that the road retains its load-bearing capacity. The road must be sufficiently wide (at least 4.5 m), and there must be no obstructions preventing a lorry from driving the entire length of the road and turning at the junction (taking into account factors such as roadside trees, rocks, sharp turns and overhead cables).

The maximum dimensions and weights of lorries shall be as follows:

Maximum width:	2.6 m
Maximum length:	25.25 m
Maximum height:	4.4 m
Maximum total weight:	44,000 kg

The space required for lorries to turn and enter at the junction is shown in the turning radius diagrams below.

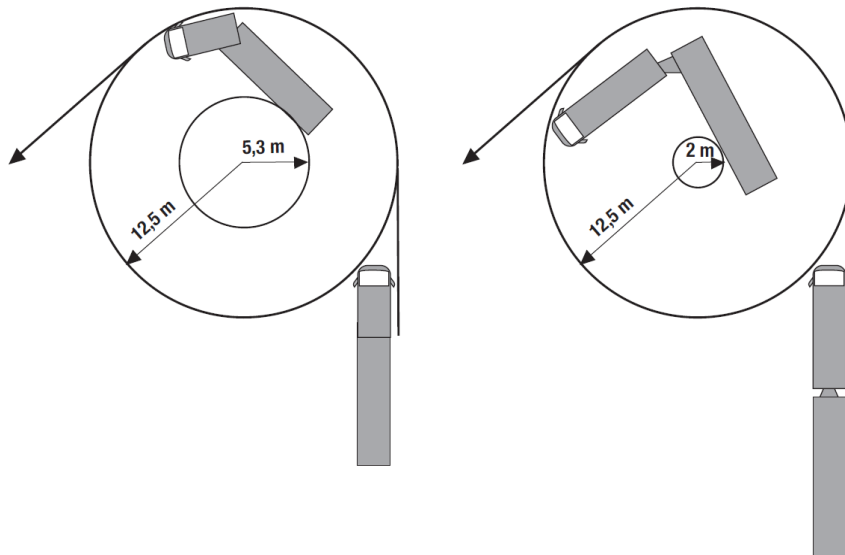

*Figure 3. Turning radii for lorries according to the requirements in the Road Traffic Act. The figure on the left is for shipments less than 18.75 m long (such as autoclaved aerated concrete products on a semi-trailer), and the figure on the right is for products more than 18.75 m long (such as roof trusses on a full trailer). According to the law, the cargo may extend by up to 2 m from the outermost part of the vehicle.*

If there are doubts about the suitability of the routes leading to the site (such as driveways, public roads, bridges, underpasses or junctions), the Delivery Manager may make special arrangements in advance to use a smaller vehicle to transport products that would normally be transported on a full trailer. Such changes shall give rise to additional costs for which the Client shall be liable. Making special arrangements for autoclaved aerated concrete products that are normally delivered on semi-trailers has a greater cost impact, so it is advisable to ensure that semi-trailer deliveries can be made to the construction site.

Ultimately, the carrier shall evaluate the roadworthiness of the road at the time of delivery and reserve the right to change the method of delivery at the Client’s expense.

## **PLANNING OF THE CONSTRUCTION SITE AREA AND UNLOADING OF GOODS**

Goods shall generally be unloaded using a separate truck crane or construction site crane, but a skid loader may also be used. The transportation and hoisting equipment must fit on the construction site at the same time. If transportation cannot be handled using fully-loaded lorries with semi-trailers and full trailers due to a lack of space on the plot or in the unloading place or if the Client cannot specify an unobstructed unloading place in the immediate vicinity of the construction area, the Client shall be liable for the costs incurred due to extra hoisting, transfers and deliveries. If the Client wishes to have the products in smaller batches than agreed, the Client shall be liable for the cost impact of the change.

## **RECEPTION OF DELIVERIES**

- Deliveries shall be delivered as agreed and in phases according to progress on the construction site.
- The Client must prepare a storage area for the products delivered to the plot so that the transportation vehicle has unobstructed access to unload the goods. The storage area must have a hard base and be sufficiently flat. The area must be large enough to receive a full load (approx. 50 m<sup>2</sup>).
- If it is necessary to unload goods into the storage area from a public road due to the small size of the plot, the Client must find out, handle and pay the costs of the permits and actions related to road closures.
- If a delivery is found to contain deficiencies or visible defects or to have been substantially delayed, the matter shall be noted on the waybill and reported to the Delivery Manager and the relevant supplier immediately.

## **PROBLEMS, COMPLAINTS AND FEEDBACK**

In the event of any problems related to the quality of products, delivery errors, design and installation, the Client should always contact the Delivery Manager in the first instance.

Complaints about errors in the delivery or goods must be submitted to the Delivery Manager within a reasonable time, which may be no later than one month after the Client noticed or should have noticed the error. If a complaint is not submitted within the time limit specified above, the Client may forfeit its right to invoke the error. Complaints shall be made in writing to Jämerä, which endeavours to respond to all complaints in writing without delay.

Feedback may also be sent by email to [jamera-toimitukset@jamera.fi](mailto:jamera-toimitukset@jamera.fi).